

AIR CONDITIONING - MECHANICAL INDOOR UNITS									
REFERENCE	DESCRIPTION	TOTAL COOLING (kW)	HEATING (kW)	INDOOR MODEL	OUTDOOR MODEL	INDOOR DIMENSIONS (HXWxD)	WEIGHT (KG)	PIPE SIZE	MANUFACTURER
AC1	HIGH WALL	5	6	FTXS50LVMA	RXS50LVMA (OU1)	340X1050X248	14	6.4 & 12.7	DAIKIN
AC2	HIGH WALL	5	6	FTXS50LVMA	RXS50LVMA (OU2)	340X1050X248	14	6.4 & 12.7	DAIKIN
AC3	DUCTED	7.1	7.5	FDYQ71LAV1	RZQ71AV1	360x1188x869	47	9.5 & 15.9	DAIKIN

AIR CONDITIONING - MECHANICAL OUTDOOR UNITS							
REFERENCE	DESCRIPTION	INDOOR MODEL	OUTDOOR MODEL	DIMENSIONS (HXWxD)	WEIGHT (KG)	PIPE SIZE	MANUFACTURER
OU1	SPLIT SYSTEM	FTXS50LVMA (AC1)	RXS50LVMA	735X825X300	46	6.4 & 12.7	DAIKIN
OU2	SPLIT SYSTEM	FTXS50LVMA (AC2)	RXS50LVMA	735X825X300	46	6.4 & 12.7	DAIKIN
OU3	SPLIT SYSTEM	FDYQ71LAV1 (AC3)	RZQ571AV1	990x940x320	75	9.5 & 15.9	DAIKIN

AIR-HANDLING UNITS							
REFERENCE	DESCRIPTION	SUPPLY AIR FLOW (L/S)	FAN MOTOR POWER (kW)	COOLING COIL DUTY (kW)	HEATING COIL DUTY (kW)	COMMENTS	WEIGHT (kg)
AHU1	MC SERIES AIR HANDLING UNIT	6700	15	196	150		1500
AHU2	MC SERIES AIR HANDLING UNIT	5400	11	155	117		1190
AHU3	MC SERIES AIR HANDLING UNIT	3700	11	141	83		970

FANS - EXHAUST AND SUPPLY COWL														
REFERENCE	MODEL	TYPE	SERVES	AIRFLOW (L/S)	ESP (PA)	SPEED CONTROL	MAX SPEED - RPM	POWER(KW)	CURRENT (FL-AMPS)	PHASE 1Ø OR 3Ø	VOLTS	WEIGHT (KG)	UPSTAND SIZE (EXTERNAL)	MANUFACTURER
TEF1	TD 1300 / 250	MIXED FLOW	CHANGING ROOMS	TBC	TBC	VA	1980	0.14	0.6	1	240	9.4	TBC	FANTECH
TEF2	TD 1300 / 250	MIXED FLOW	TOILET EXTRACT	TBC	TBC	VA	1980	0.14	0.6	1	240	9.4	TBC	FANTECH
SAF1	TD 1300 / 250	MIXED FLOW	LAB, MCC, HYGENE FRESH AIR	TBC	TBC	VA	1980	0.14	0.6	1	240	9.4	TBC	FANTECH

FILTERS					
REFERENCE	MODEL	DESCRIPTION	LISTED SIZE	SYSTEM	MANUFACTURER
F1	FGR250	G4 FILTER	Ø250	SAF1	FANTECH

GRILLES & LOUVRES (SUPPLY AND RETURN)					
REFERENCE	MODEL	AIRFLOW (L/S)	COLOUR	SIZE (W x H)	MANUFACTURER
S1	DDL-20	TBC	TBC	TBC	HOLYOAKE
S2	CMP-A-41	TBC	TBC	TBC	HOLYOAKE
S3	DDL-32 / OBD	TBC	TBC	TBC	HOLYOAKE
S4	DDL-32 / OBD	TBC	TBC	1000x1000	HOLYOAKE
S5	CMP-A-41	TBC	TBC	550x550	HOLYOAKE
E1	EC-125	TBC	TBC	TBC	HOLYOAKE
E2	EC-125	TBC	TBC	595x595	HOLYOAKE
E3	EC-125	TBC	TBC	1000x1000	HOLYOAKE

7c Furnace Place Silverdale, Auckland. Phone: (09) 426 0332
P.O. Box 506 Orewa, Auckland NZ. Fax: (09) 426 4332



Project:
TOWER EXTENSION

Client:
NZ DAIRY COLLABORATIVE

Notes
The contractor shall check & confirm all dimensions adjusting for minor, reporting major.
Under no circumstances is TSL liable for payment of any product or service associated with the project including any error or omission resulting in any additional project cost.
All works to comply with NZBC 1991, NZS 3604; and or any relevant standards and amendments there-of.
© Design & Dwg are copyright & property of Thermal Solutions Limited.

Rev	Date	Revision Notes
A	10.03.2017	Preliminary (For Construction)
B	17.03.2017	Grilles Added

EQUIPMENT SCHEDULE			
Sheet size A3	Scale NTS	Drawn by M.F	Checked by B.E
Job # 31688	Sheet # M001_B	Date 17.03.2017	

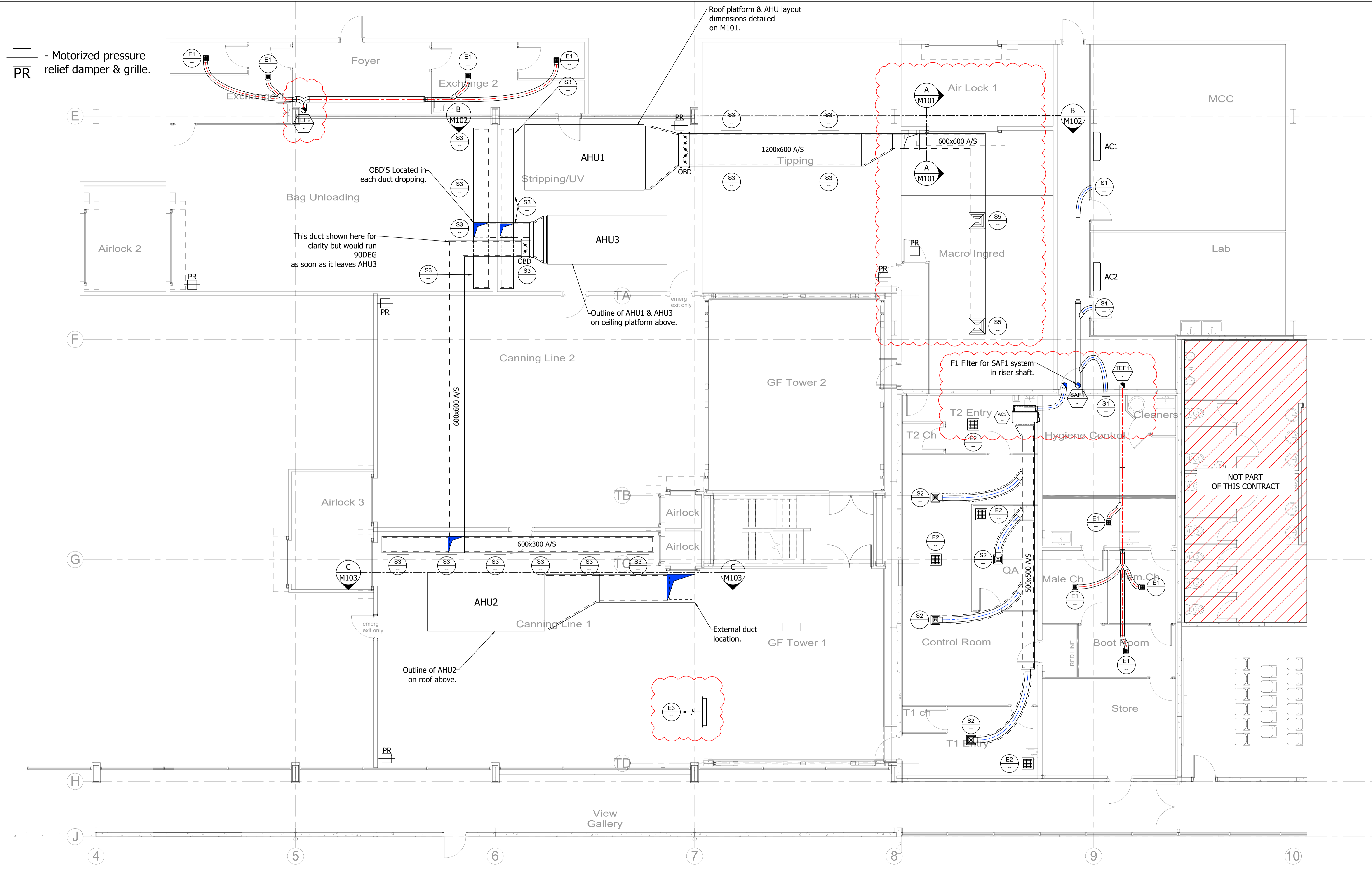

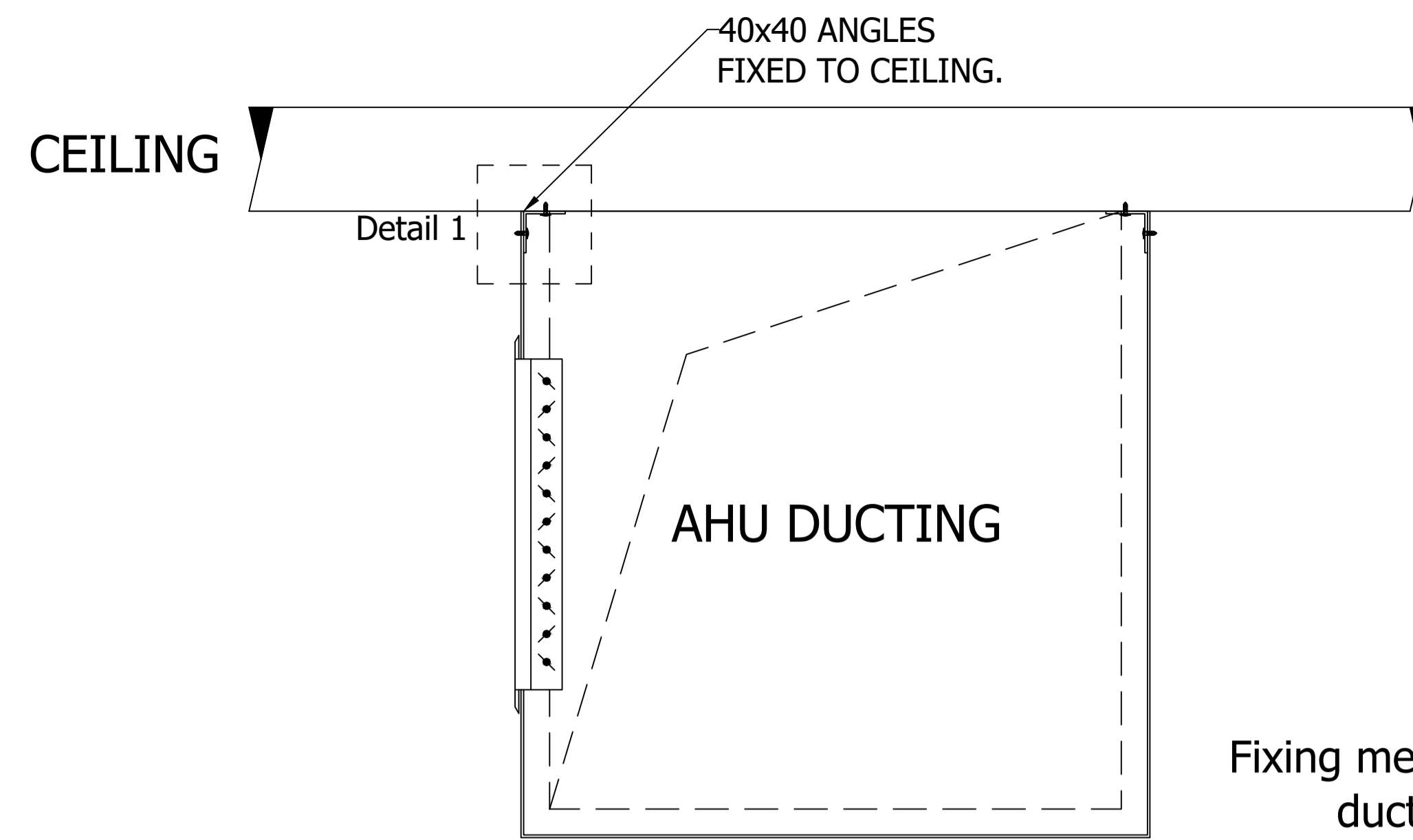
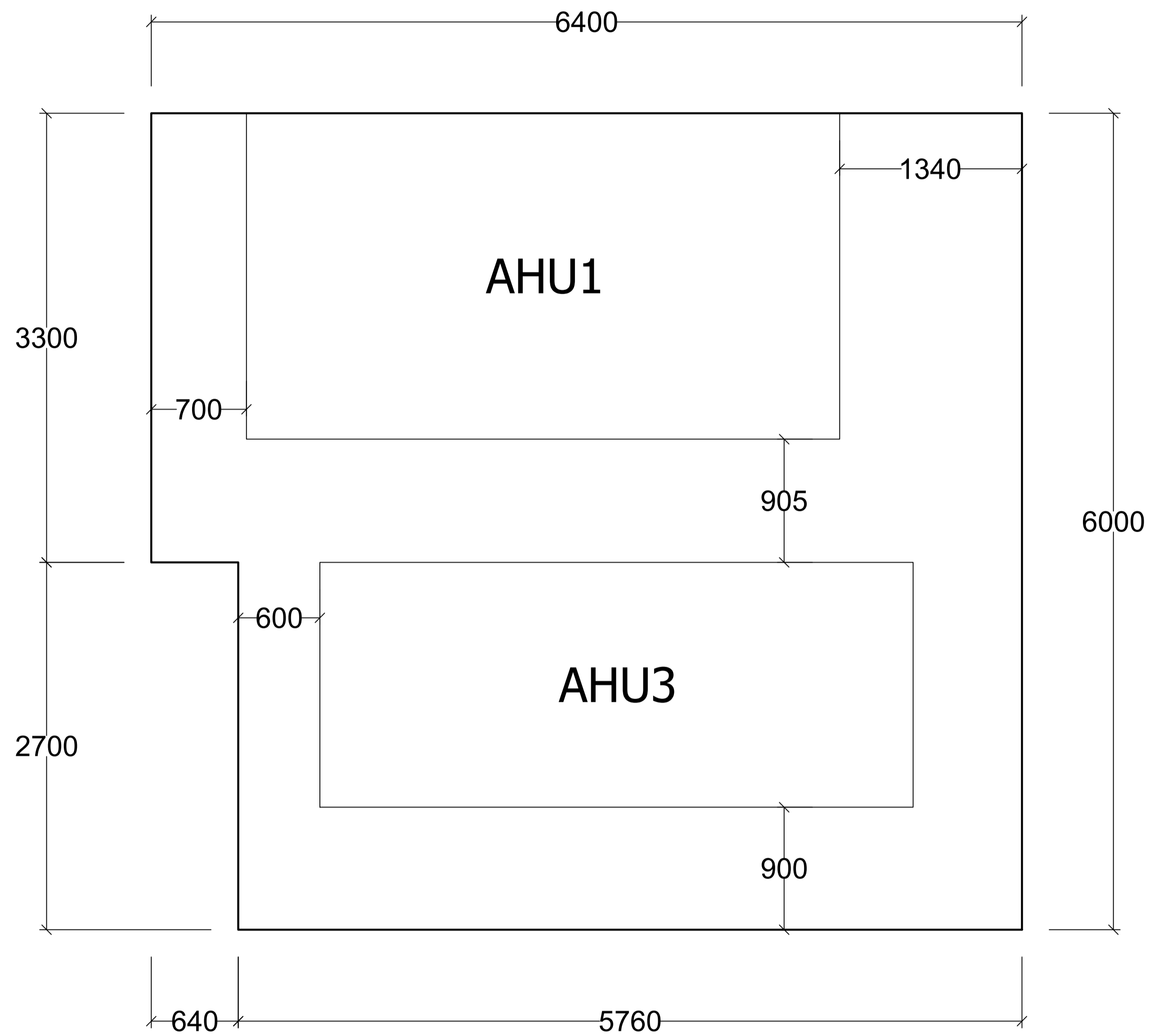

Fixing method for ducting TBC

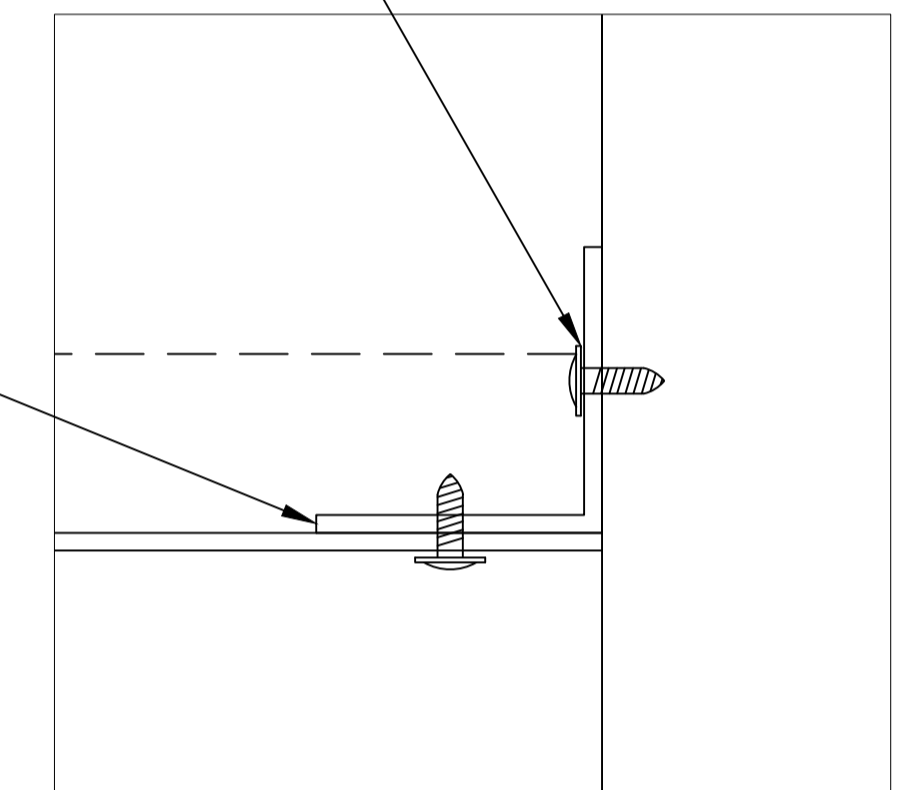

DETAIL 1 - DUCT TO COOLSTORE PANEL FIXING
SCALE:NTS

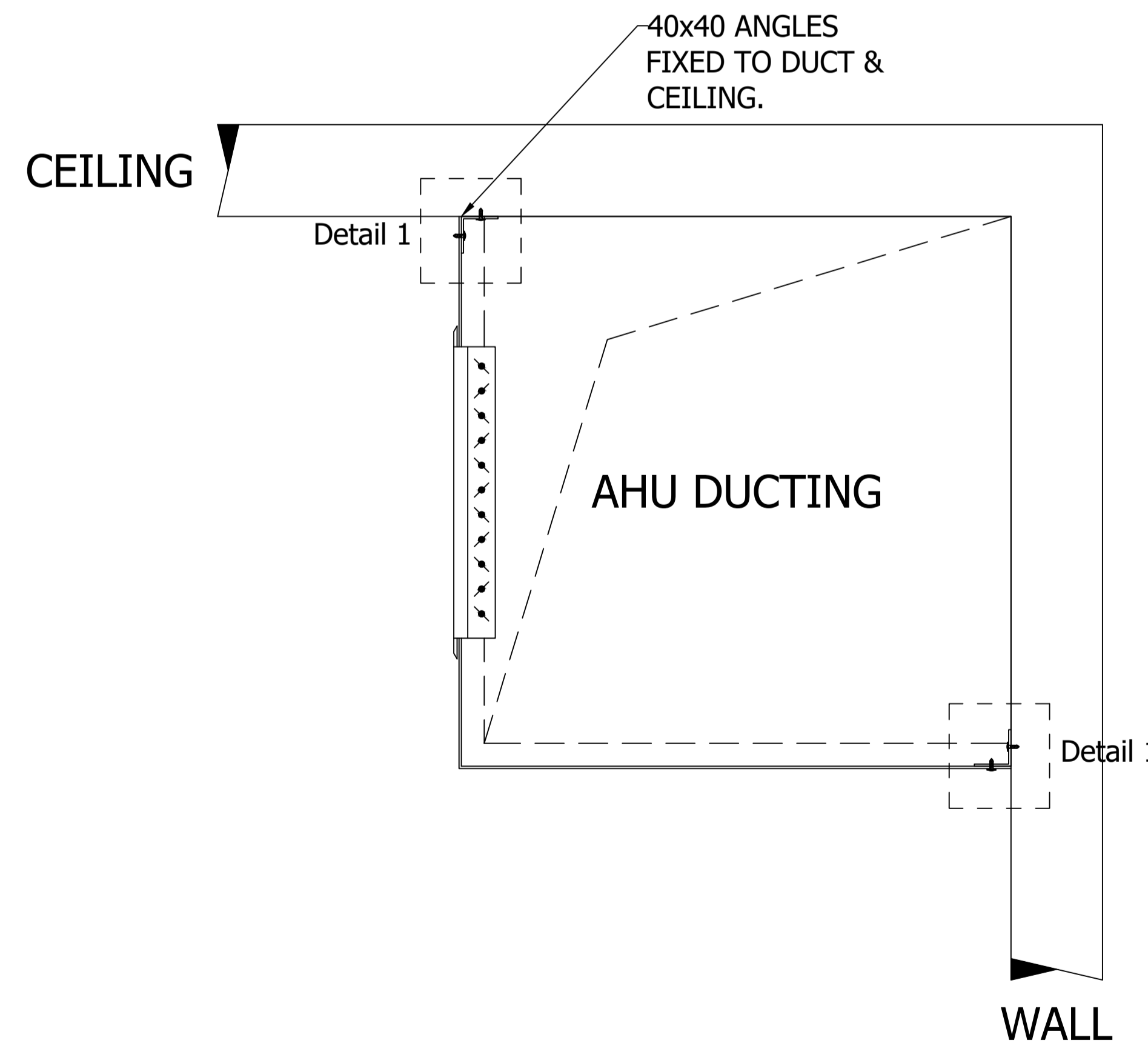

① AHU 1 & 2 Plant Deck
1:50 @ A3

Ⓐ Duct Sections
1:10 @ A3

7c Furnace Place Silverdale, Auckland. Phone: (09) 426 0332
P.O. Box 506 Orewa, Auckland NZ. Fax: (09) 426 4332



Project:

TOWER EXTENSION

Client:

NZ DAIRY COLLABORATIVE

Notes

The contractor shall check & confirm all dimensions adjusting for minor, reporting major.
Under no circumstances is TSL liable for payment of any product or service associated with the project including any error or omission resulting in any additional project cost.
All works to comply with NZBC 1991, NZS 3604; and or any relevant standards and amendments there-of.
© Design & Dwg are copyright & property of Thermal Solutions Limited.

Rev	Date	Revision Notes
A	13.03.2017	Preliminary for construction

Details / Sections 1

Sheet size A3	Scale As Shown	Drawn by M.F
Job # 31688	Sheet # M101_A	Checked by B.E
		Date 13.03.2017

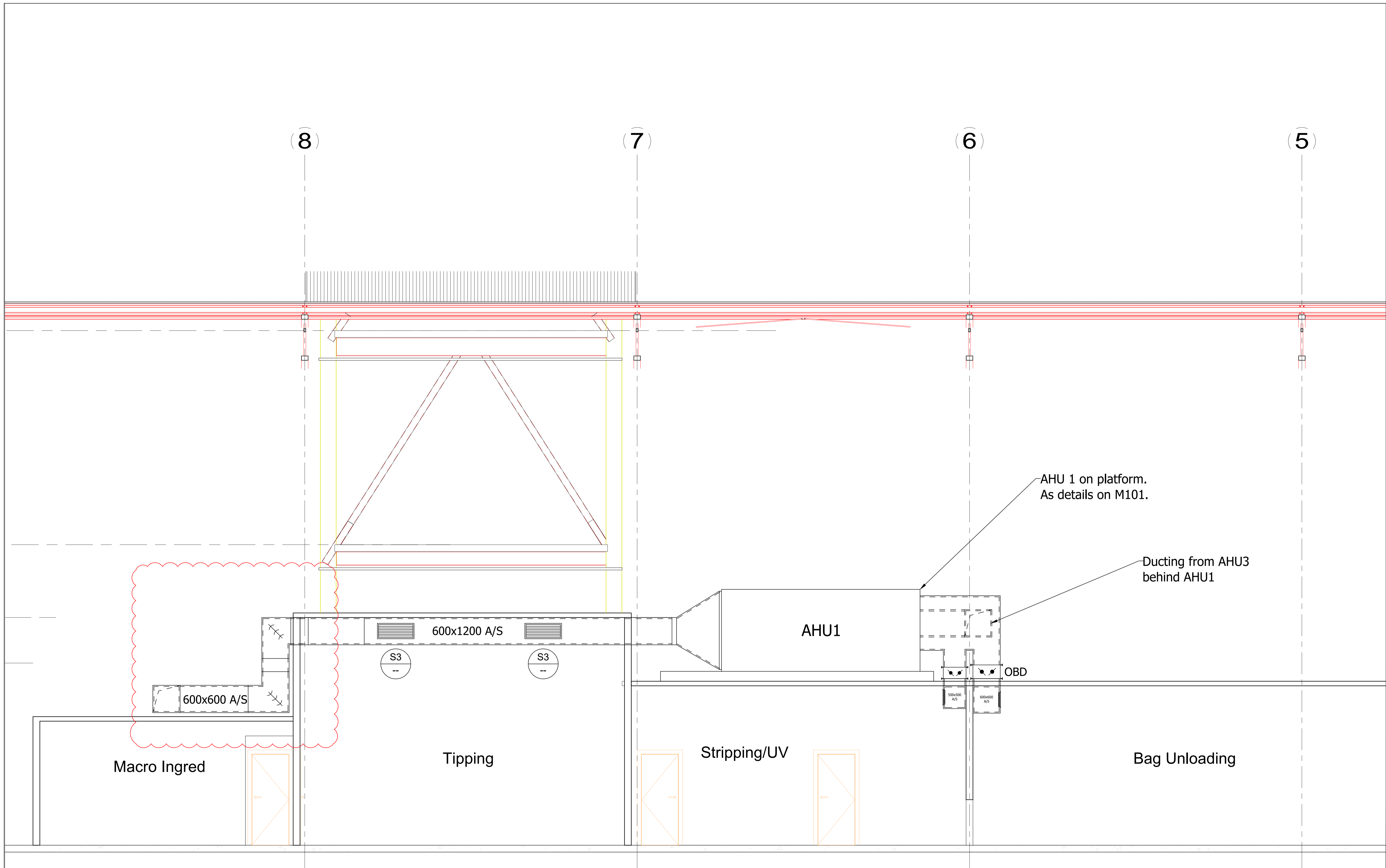

7c Furnace Place Silverdale, Auckland. Phone: (09) 426 0332
P.O. Box 506 Orewa, Auckland NZ. Fax: (09) 426 4332



Project:
TOWER EXTENSION

Client:
NZ DAIRY COLLABORATIVE

Notes
The contractor shall check & confirm all dimensions adjusting for minor, reporting major.
Under no circumstances is TSL liable for payment of any product or service associated with the project including any error or omission resulting in any additional project cost.
All works to comply with NZBC 1991, NZS 3604; and or any relevant standards and amendments there-of.
© Design & Dwggs are copyright & property of Thermal Solutions Limited.

Rev	Date	Revision Notes
A	13.03.2017	Preliminary for construction
B	17.03.2017	Preliminary for construction
C	26.04.2017	Amended duct run.

Section B

Sheet size A3	Scale 1:75 @ A3	Drawn by M.F
Job # 31688	Sheet # M102_C	Checked by B.E
		Date 26.04.2017

● Tower Knee
18990

● Level T4
15600

● Level T3
11300

● Level T2
6600

● Level T1
4000

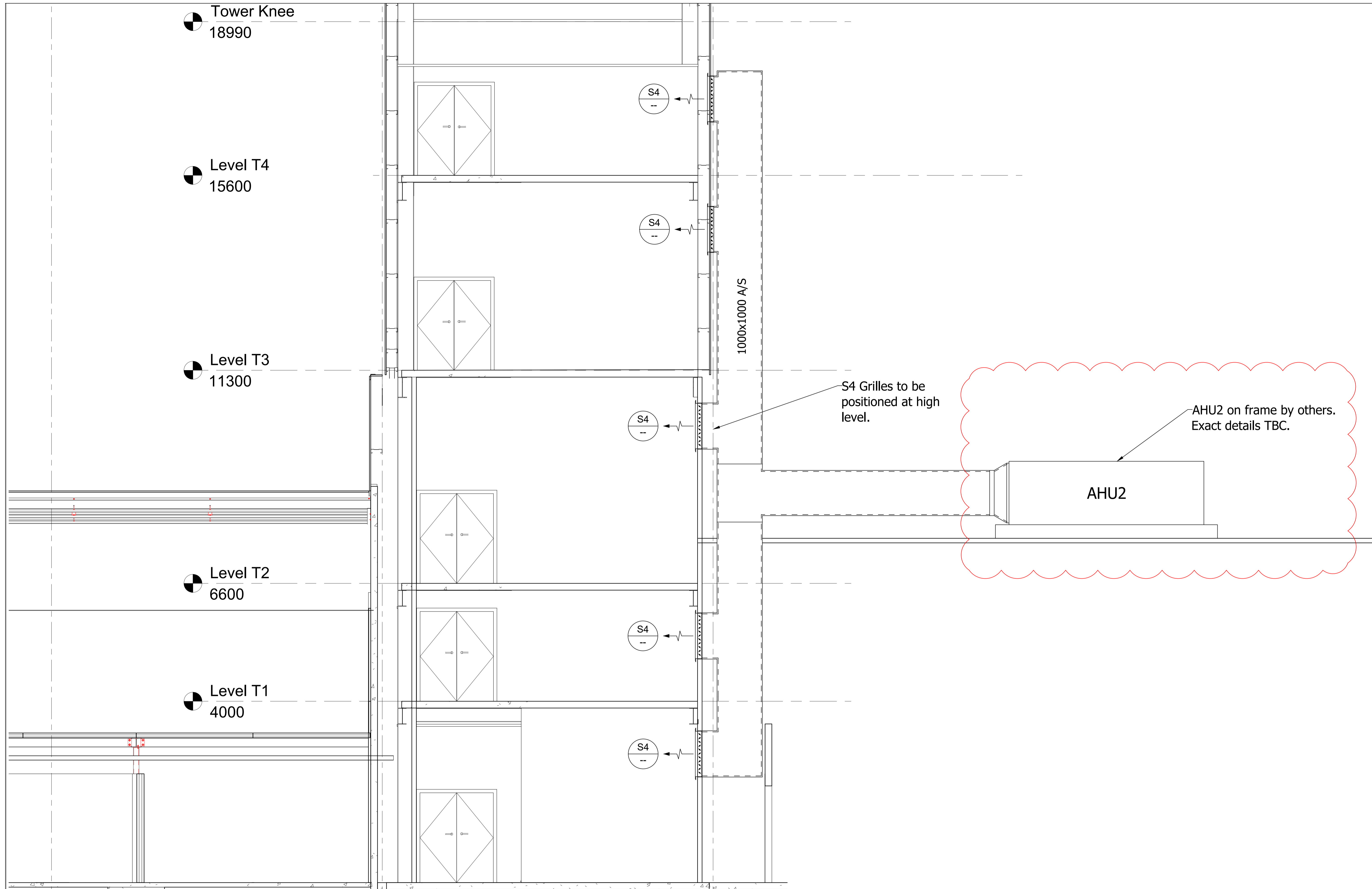

7c Furnace Place Silverdale, Auckland. Phone: (09) 426 0332
P.O. Box 506 Orewa, Auckland NZ. Fax: (09) 426 4332

Project:
TOWER EXTENSION

Client:
NZ DAIRY COLLABORATIVE

Notes
The contractor shall check & confirm all dimensions adjusting for minor, reporting major.
Under no circumstances is TSL liable for payment of any product or service associated with the project including any error or omission resulting in any additional project cost.
All works to comply with NZBC 1991, NZS 3604; and or any relevant standards and amendments there-of.
© Design & Dwg's are copyright & property of Thermal Solutions Limited.

Rev	Date	Revision Notes
A	13.03.2017	Preliminary for construction
B	14.03.2017	Amended AHU3 Location.

Section C			
Sheet size A3	Scale 1:75 @ A3	Drawn by M.F	Checked by B.E
Job # 31688	Sheet # M103_B	Date 14.03.2017	

